



Street cleaning cart for two bins h140_371

Galvanized steel street cleaning cart for two bins. With 600 mm diameter wheels

Hand cart for urban waste collection, with a structure made of **galvanized steel** round tube with **storage tray** and **clamps for locking the bins**, **tool holders** positioned on both sides. **Spoked wheels**, made of unalterable solid rubber, **diam. 600 mm**. The cart is suitable for transporting **2 urban waste bins** of **100 liters each**, **not included**. The base finish of the product is **agate grey RAL 7038**. The painting technique used is **thermosetting powder coating** oven-baked at 180°.

Technical Features:

- Structure material: galvanized steel round tube
- Storage tray
- Suitable for 2 bins (not included)
- Tools not included
- Clamps for locking the bins
- Tool holders on both sides
- Solid rubber spoked wheels diameter 600 mm
- Color: RAL 7038 agate grey

Optional:

- 2 x 100-liter PVC bins with book-hinged lid, manually tiltable at the back. With side handles. Black color.

*upon request, the cart can be ordered in different colors

INFORMATION

- **tipologia** Utilizzabile con bidone
- **Length in millimeters** 1400.000000
- **Depth in millimeters** 600.000000
- **Height in millimeters** 900.000000



HOLITY.COM



HOLITY.COM

Street cleaning cart for two bins h140_371

Tipologia: Utilizzabile con bidone

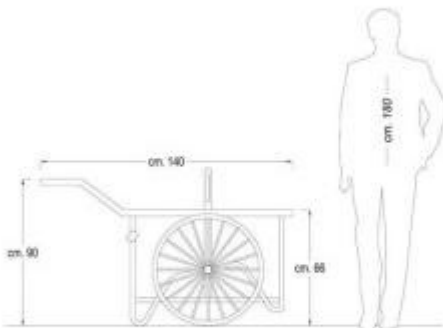

HOLITY.COM