



## Pediatric examination couch h666\_01

Metal infant examination couch with fireproof padded top, drawer, and bottom shelf. Height 85 cm, load capacity 80 kg. For pediatric clinics and neonatal wards.

The examination couch is specifically designed for the clinical examination of newborns and infants in a medical environment. It guarantees maximum comfort for the small patient during the medical visit and facilitates physician access for diagnostic procedures. The stable structure allows working in complete safety in pediatric, obstetric, and neonatal ward contexts.

## Technical specifications

- **Supporting structure:** metal with silver-grey color
- **Height:** 85 cm
- **Upper top:** foam padding with M1 class fireproof covering, available in various colors
- **Containment edges:** present on 3 sides for greater safety of the newborn
- **Drawer:** dimensions 60 x 40 cm for storing small supplies or instruments
- **Bottom shelf:** made of wood for storing objects
- **Load capacity:** 80 kg

## Options

- Paper roll holder
- Set of 4 wheels with brake, diameter 120 mm

*Image purely indicative*

## INFORMATION

- **Height** 85 cm
- **capacity** 80 kg

## Pediatric examination couch h666\_01

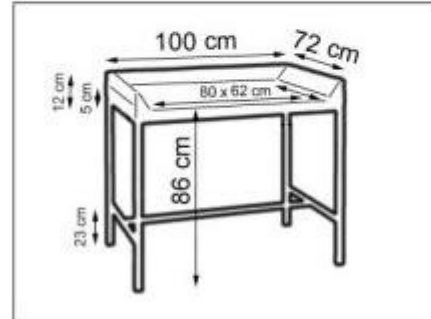

## Pediatric examination couch h666\_01

Height: 85 cm  
Capacity: 80 kg

