

CERTIFICAZIONE
SICUREZZA VETRO



CERTIFICAZIONE
RESISTENZA AL FUOCO

HOLITY.COM

Notice board h738_91

Notice board ideal for offices. 9 x A4 format. Magnetic back. Dimensions: W. 72 x D. 5.9 x H. 98.2 cm

Notice board suitable for restaurants, hotels, offices. The notice board features **sliding doors** and a writable **magnetic** surface. The structure is made of anodized aluminum and ABS corners. Closing **with lock** and transparent tempered glass door. The office notice board is **ESG and B1 certified**.

Technical Features:

- Material: aluminum and glass
- For indoor use
- With lock
- Wall mounting
- With sliding doors
- 9 x A4 format
- Dimensions: W. 72 x D. 5.9 x H. 98.2 cm

INFORMATION

- **Tipo fondo** Fondo magnetico
- **Opening** Ante scorrevoli

Notice board h738_91



HOLITY.COM



HOLITY.COM



HOLITY.COM

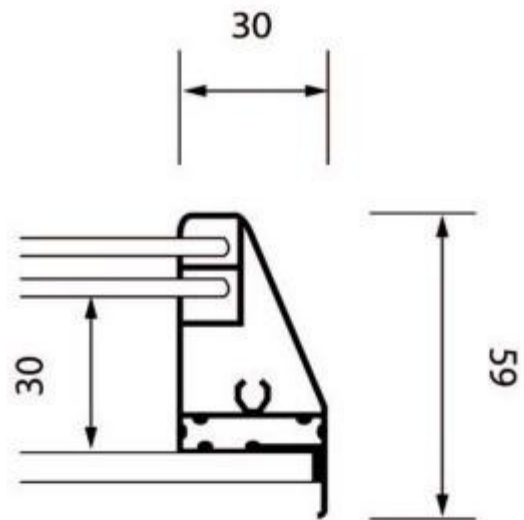

HOLITY.COM

Notice board h738_91

Tipo fondo: Fondo magnetico
Opening: Ante scorrevoli