



Mortuary transport stretcher h812_03

Stainless steel stretcher for the transport of deceased in hospital environments, with rotating cover and braking system on wheels, load capacity 300 kg.

The **mortuary transport stretcher** represents a specialized solution for hospitals and healthcare facilities requiring discretion and professionalism in the management of the deceased. Made entirely of **stainless steel**, it guarantees hygiene, durability, and ease of cleaning. The **rotating cover** ensures maximum privacy during transport within healthcare facilities, addressing both functional needs and respect for families.

Technical features

- **Material:** stainless steel
- **Wheels:** polymer with braking system (2 wheels with brake, 2 wheels without brake)
- **Cover:** rotating
- **Maximum capacity:** 300 kg
- **Dimensions:** L. 208 x D. 78 x h. 116 cm

Image for illustrative purposes only

INFORMATION

- **Typology** with cupola

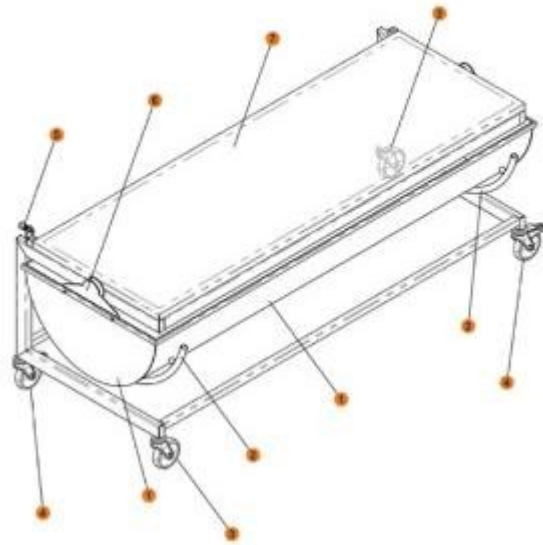

1. CUPOLA SUPERIORE ACCIAIO INOX
2. MANIGLIONE PER ROTAZIONE
3. RUOTA PIRETTANTE
4. RUOTA CON FRENO
5. BLOCCO ROTAZIONE CUPOLA
6. PERNO ROTAZIONE
7. PIANALE

Mortuary transport stretcher h812_03

Typology: with cupola