



Meeting room armchair with writing tablet h776_46

Conference armchair in faux leather with anti-panic writing tablet, steel and wood frame. Dimensions 65.5x66.5 cm, stackable. The **conference armchair** is designed for the arrangement of executive spaces, conference halls, and corporate environments intended for training. The seat is engineered to ensure prolonged ergonomic support, solving the need for mobile yet extremely stable workstations thanks to the base equipped with **4 nylon feet**. The integration of the **thermoplastic tablet with anti-panic joint** in aluminum makes it a complete solution for seminars and workshops, allowing the user to easily work with paper supports or digital devices.

Technical features

- **Total dimensions:** W.65.5 x D.66.5 x h.85 cm
- **Seat height:** 47.5 cm
- **Internal frame:** Supporting structure in steel and wood
- **Padding:** Differentiated density polyurethane resins, cold-foamed and cut from block
- **Upholstery:** Professional faux leather
- **Base:** 4 non-slip black nylon feet
- **Included accessories:** Black thermoplastic tablet with brushed and polished aluminum anti-panic joint
- **Storage:** Horizontal stackability function
- **Customization:** Available in different color variants
- **System certifications:** UNI EN ISO 9001:2015, UNI EN ISO 14001:2015, UNI ISO 45001:2018

Image for illustrative purposes only

INFORMATION

Meeting room armchair with writing tablet h776_46

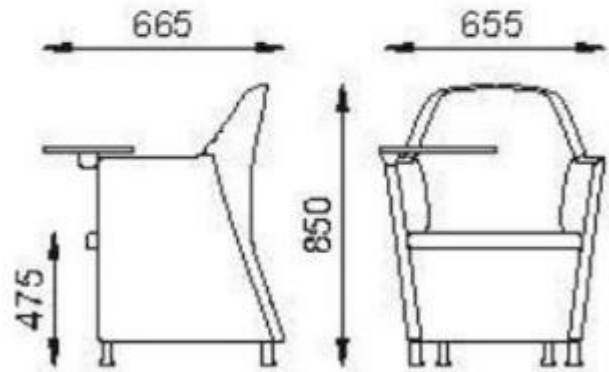

HOLITY.COM

HOLITY.COM



HOLITY.COM