



## Meeting room armchair with tablet h80\_28

Armchair for meeting rooms with writing tablet. Dimensions: W.63 x D.61 x h.86 cm. Base complete with wheels.

**Armchair for setting up conference rooms**, multipurpose rooms, congress halls, meeting points and theaters. Realized with **high-quality materials** and designed to ensure comfort and practicality of use. The structure features an internal steel part, cold-molded foam padding and **100% polyester fabric upholstery**. Equipped with **4 feet** at the base that guarantee excellent stability and supplied complete with a **tablet/writing desk** to allow the user to take notes. Ensures practical and easy storage thanks to the **fully foldable and stackable structure**.

### **Technical features:**

- Dimensions: W.63 x D.61 x h.86 cm
- Seat height: 46 cm
- Internal steel structure
- Cold-molded foam padding
- 100% polyester fabric upholstery
- Foldable and stackable
- With 4 feet at the base
- **With tablet/writing desk**
- Available in several colors

*\*\*Other colors are available upon request*

## INFORMATION

## Meeting room armchair with tablet h80\_28



HOLITY.COM



HOLITY.COM



HOLITY.COM

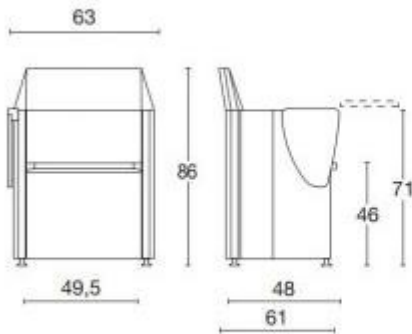

HOLITY.COM



HOLITY.COM