



Meeting armchair with wheels and writing tablet h80_29

Meeting room armchair with writing tablet and wheels. Dimensions: W.63 x D.61 x h.88 cm. Available in multiple colors.

Armchair for congresses and conference rooms, designed to provide comfort and practicality in setting up spaces dedicated to associative or institutional events. Consisting of a completely **foldable and stackable** structure, furthermore the presence of **wheels at the base**, makes it extremely manageable. Internally built in steel and padded with cold-molded foam; the upholstery is in **100% polyester fabric** and is available in multiple colors. The armchair is supplied complete with a **writing tablet** to allow writing and taking notes.

Technical characteristics:

- Dimensions: W.63 x D.61 x h.88 cm
- Seat height: 48 cm
- Internal steel structure
- Cold-molded foam padding
- 100% polyester fabric upholstery
- Foldable and stackable
- **With 4 wheels at the base**
- **With writing tablet/desk**
- Available in multiple colors

***Other colors are available on request*

INFORMATION

Meeting armchair with wheels and writing tablet h80_29



HOLITY.COM

HOLITY.COM

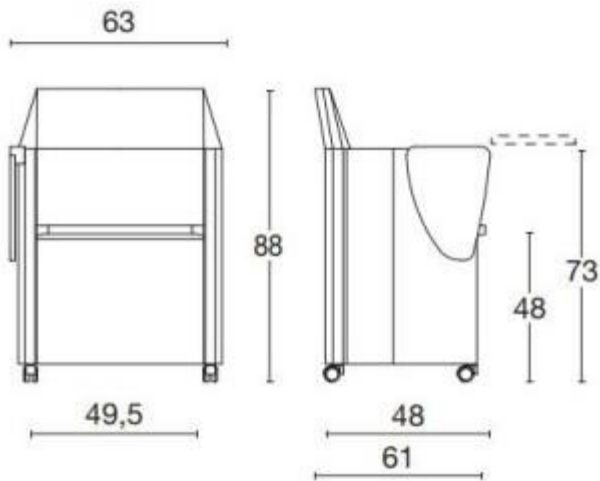

HOLITY.COM

HOLITY.COM