



Medical treatment table for Bobath therapy h581_29

2-section treatment table for Bobath method therapies. Electrically height-adjustable. Dimensions: L.200 x D.100 x h.49-90 cm.

Treatment table for clinics, medical offices and physiotherapy studios, ideal for patient care using the Bobath method. Consisting of a metal load-bearing structure designed to allow the passage of a patient lift if necessary. The **surface is padded and upholstered with fire-retardant materials** and is characterized by its large dimensions that allow for the necessary maneuvers for patient rehabilitation. The **height can be electrically adjusted by foot pedal** and the **headrest is tiltable with a gas spring**.

Technical features:

- Dimensions: L.200 x D.100 x h.49-90 cm
- Lift clearance: 15 cm
- Capacity: 350 kg
- Electrically height-adjustable with foot pedal control
- Tiltable headrest with gas spring +60°
- Fire-retardant padding and upholstery class: 1 IM
- Padding density and thickness: 30 (kg/m³) / 40 mm
- Available in several colors

Options:

- set of 4 wheels

***Image for illustrative purposes only (wheels are not included, add them as options)*

INFORMATION

- **Type** Altezza regolabile elettronicamente
- **Base material** Metal
- **Length in millimeters** 2000.000000
- **Depth in millimeters** 1000.000000
- **Height in millimeters** 490.000000

Medical treatment table for Bobath therapy h581_29

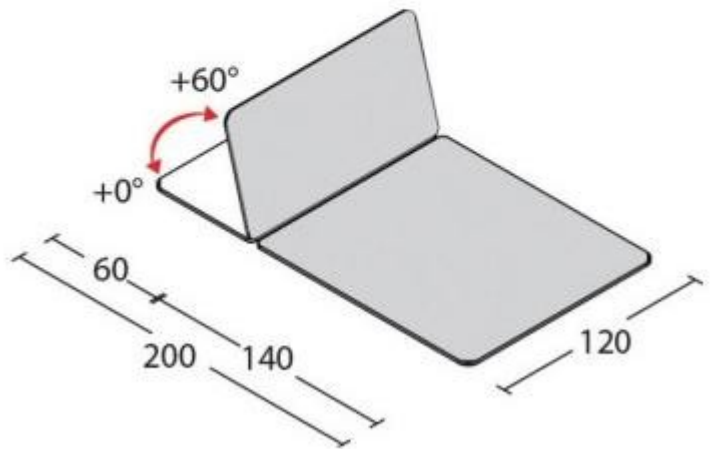

HOLITY.COM

HOLITY.COM

Medical treatment table for Bobath therapy h581_29

Type: Altezza regolabile elettronicamente
Base material: Metallo



HOLITY.COM