



HOLITY.COM

Inclusive sandbox with kaleidoscope h763_10

Inclusive sandbox made of polyethylene and powder-coated steel with kaleidoscope. Suitable for children with disabilities. Dimensions: 1.36 x 1.19 x 1.21 m. TÜV SUD EN 1176 certification.

The inclusive sandbox represents a playful and therapeutic tool specifically designed for playgrounds, gardens, playrooms, and kindergartens. It allows children to manipulate sand, developing fine motor skills, hand-eye coordination, and awareness of manual movements through free play and sensory discovery.

A distinctive feature is its **total accessibility**: the design allows for approach to the play table both while seated and standing, making it **suitable for use by children with motor disabilities**. The table is equipped with an **integrated kaleidoscope** that allows children to observe the creations made with sand up close, adding a sensory and visual dimension to the game.

The structure combines **polyethylene and powder-coated steel**, materials selected to ensure durability, ease of maintenance, and safety in environments exposed to the elements.

Technical features

- Inclusive sandbox with facilitated access
- Equipped with an integrated kaleidoscope
- Structure in polyethylene and powder-coated steel
- Dimensions: length 1.36 m x depth 1.19 m x height 1.21 m
- Required impact surface: 14 m²
- Age group: 1-12 years
- Free fall height: 0.3 m
- Minimum installation space: 4.55 m x 3.89 m
- TÜV SUD EN 1176 certification (safety for playground equipment)

Image for illustrative purposes only

INFORMATION

- Length in millimeters 1367.000000
- Depth in millimeters 1190.000000
- Height in millimeters 1210.000000

Inclusive sandbox with kaleidoscope h763_10



HOLITY.COM



HOLITY.COM



HOLITY.COM

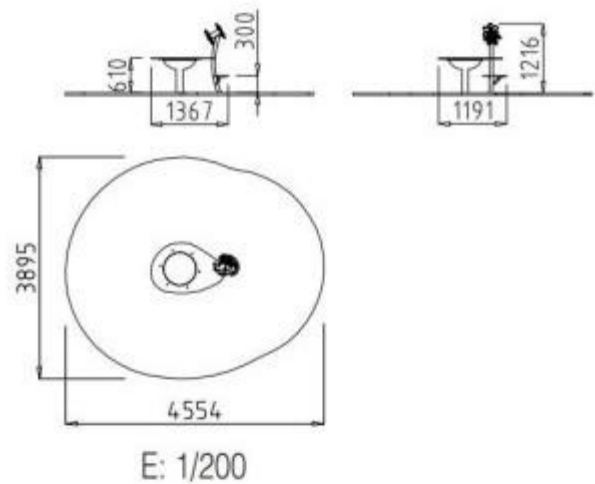

HOLITY.COM