



Inclusive sandbox for play areas h763_11

Inclusive wooden sandbox for children aged 1-12, structure 2.71x2.71x0.87 m, pressure-treated wood and plywood, TÜV SUD EN 1176 certified.

The sandbox is an educational tool designed to stimulate children's creativity and manual skills through free play and sand manipulation. This version features an **inclusive structure** specifically designed to accommodate children with disabilities, ensuring access and usability for a wide age range, from 1 to 12 years. The construction with robust and treated materials ensures long-term durability and resistance to weathering, while the compact design allows it to be integrated into public and private spaces with reduced footprints.

Technical features

- **Structure:** Inclusive, accessible to children with disabilities
- **Age range:** 1–12 years
- **Structure dimensions:** Length 2.71 m, Depth 2.71 m, Height 0.87 m
- **Weight:** 20 kg
- **Free fall height:** 0.37 m
- **Minimum space required:** 5.71 × 5.71 m
- **Impact surface:** 30.7 m²
- **Materials:** Glued laminated timber, pressure-treated wood, plywood panel, polyethylene
- **Certification:** TÜV SUD EN 1176
- **Color:** Yellow side bars, green round corner elements

Image for illustrative purposes only

INFORMATION

- **Length in millimeters** 2710.000000
- **Depth in millimeters** 2710.000000
- **Height in millimeters** 870.000000



HOLITY.COM



HOLITY.COM



HOLITY.COM

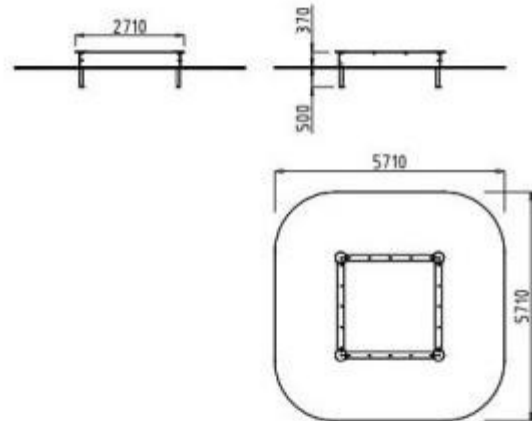

E: 1/200

HOLITY.COM