



Hospital patient stretcher h666_24

2-section patient transport stretcher. Dimensions: W.164 x D.52.5 x H.84 cm. Capacity: 150 kg.

Hospital stretcher for hospitals, clinics and nursing homes, ideal for transporting patients across various departments. Consisting of a **painted steel base** equipped with **4 wheels and push handles** to allow for rapid movement. The surface features **high-density padding** and a **manually adjustable headrest via ratchets**. The structure is also complete with a **pair of foldable side rails**.

Technical features:

- Dimensions: W.164 x D.52.5 x H.84 cm
- Capacity: 150 kg
- Adjustable headrest via ratchets from 0° to 75°
- High-density padded surface 4kg/cm², thickness 6 cm
- Push handles
- Foldable side rails
- Painted steel structure
- 4 wheels diam. 125 mm with independent brake

INFORMATION

- Height in millimeters 840.000000
- Length in millimeters 1640.000000
- Depth in millimeters 525.000000
- Typology Altezza fissa

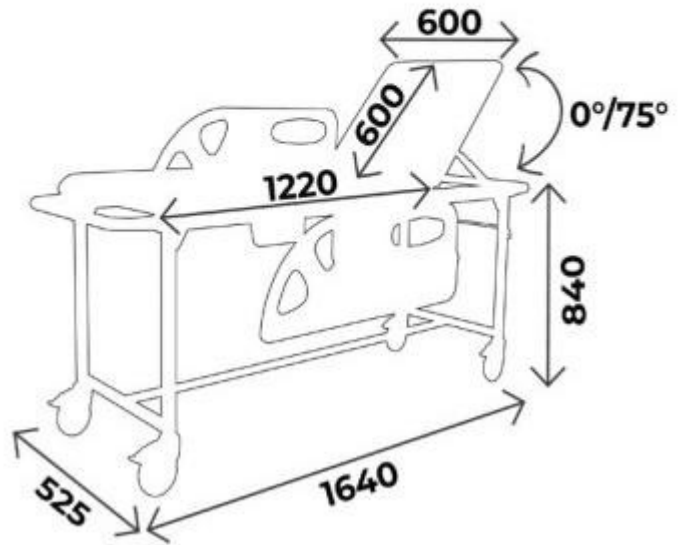

HOLITY.COM

HOLITY.COM



Hospital patient stretcher
h666_24

Typology: Altezza fissa



HOLITY.COM