



Gynecological examination chair h728_05

3-motor electric gynecological chair in painted steel and fireproof vinyl. Trendelenburg and height adjustment for professional clinical use.

The **gynecological examination chair** is a specialized medical device designed for intensive use in hospital settings and private clinics. The supporting structure is made of **steel with an epoxy coating**, ensuring mechanical resistance and stability during diagnostic procedures. The surface is padded with high-density foam (30 kg/m³) and upholstered in **certified class 11M fireproof vinyl**, combining patient comfort with compliance with fire safety regulations.

The movement system uses **3 electric motors** managed via remote control, which allow for millimeter adjustment of the height, backrest inclination, and rapid achievement of **Trendelenburg and Anti-Trendelenburg** positions. The configuration is completed by functional accessories such as adjustable leg supports, a removable stainless steel tray, and an integrated wheel system for easy movement within outpatient spaces.

Technical features

- **Dimensions:** L 174 x W 56 x h 54/85 cm
- **Load capacity:** 180 kg
- **Frame:** Steel with white epoxy painting
- **Upholstery:** 100% class 11M fireproof vinyl
- **Padding:** 5 cm thick foam, density 30 kg/m³
- **Movement:** 3 electric motors for height, backrest, and Trendelenburg
- **Adjustable components:** Gas spring footrest, swiveling leg supports, fold-down armrests (90°-180°)
- **Included accessories:** Removable stainless steel tray, ergonomic cushion, gynecological hole, roll holder, and remote control
- **Mobility:** 4 wheels with brake ø 100 mm
- **Compliance:** CE Mark

Maintenance and cleaning: To preserve the integrity of the upholstery, avoid the use of solutions containing alcohol, ketones, xylene, or solvents. Use only soft cloths with water and neutral soap; do not use abrasive sponges or metal brushes.

Image for illustrative purposes only

INFORMATION

- **Length in millimeters** 1740.000000
- **Depth in millimeters** 560.000000
- **Height in millimeters** 540.000000
- **type height** variable
- **capacity** 180 kg



HOLITY.COM



HOLITY.COM



HOLITY.COM

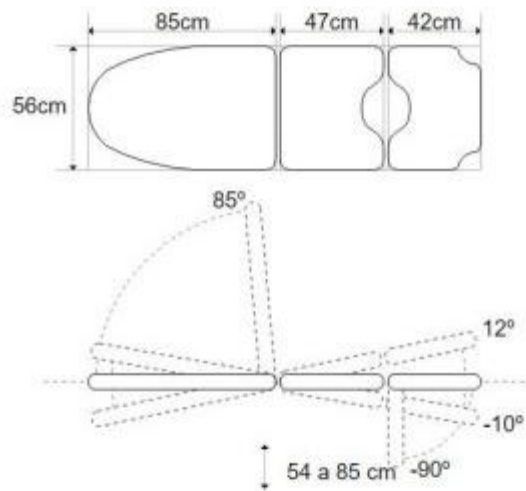

HOLITY.COM

Gynecological examination chair h728_05

Capacity: 180 kg

Type height: variable