



HOLITY.COM

Fixed height gynecology couch h581_09

Fixed height couch for gynecological examinations. Dimensions: L.185xW.62xh.76 cm

Three-section metal couch with fixed height, for therapy and medical, gynecological and urological examinations. **Leg rest and backrest** are manually adjustable. The couch is equipped with **height and rotation adjustable leg holders** and a removable **stainless steel tray**.

Technical Features:

- Structure material: chromed steel
- 3-section electric gynecological couch
- Fixed seat section
- Leg rest adjustment: manual 0°+90°
- Manual backrest adjustment 0°+75°
- Leg holder adjustment: manual height and rotation
- Stainless steel tray: removable
- Flame-retardant padding and upholstery class: 1 I M
- Padding density and thickness: 30 (kg/m3) / 50
- Dimensions: L.185xW.62xh.76 cm
- Capacity: 135 Kg

*purely indicative image, the product may undergo structural changes

Optional

- Paper roll holder applicable to the end section of the couch, designed for 60 cm high paper rolls

INFORMATION

- **Length in millimeters** 1850.000000
- **Depth in millimeters** 620.000000
- **Height in millimeters** 760.000000
- **type height** fixed
- **capacity** 135 Kg

Fixed height gynecology couch h581_09



HOLITY.COM

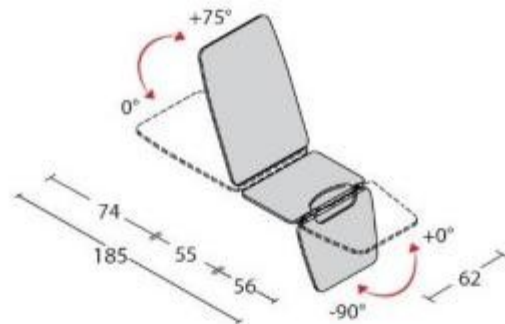

HOLITY.COM

Fixed height gynecology couch h581_09

Capacity: 135 Kg
Type height: fixed