



HOLITY.COM

Expired medicine collection bin h140_303

Expired medicine collection bin to be placed near pharmacies. Fixing: to be buried. Capacity: approximately 70 liters.

Expired medicine collection container ideal for placement near pharmacies and doctors' surgeries. **Circular-shaped** expired medicine container made of galvanized sheet metal complete with a sign indicating the type of waste. Waste disposal is performed by **lifting (opening) the flap**; a special system prevents the retrieval of medicines once they have been placed in the bin. Ground fixing is achieved **by extending the support post** into the ground.

Technical features:

- Galvanized steel structure
- Steel sheet container
- Bin color: gunmetal grey
- Lid color: traffic white RAL 9016
- Equipped with a universal key lock and a sign indicating the type of collection
- Fixing: to be buried
- Capacity: approximately 70 liters
- Height above ground: 130 cm
- Part to be buried: 20 cm
- Depth: 55 cm
- Bin dimensions: Ø 35 x h.74 cm

INFORMATION

- Capacity 70 lt
- Height in millimeters 1300.000000
- Width in millimeters 350.000000
- Depth in millimeters 550.000000



HOLITY.COM



HOLITY.COM

DIMENSIONI

Altezza fuori terra cm. 130;
Parte da interrare cm. 20;
Profondità totale cm. 55;
Diametro cesto cm. 35;

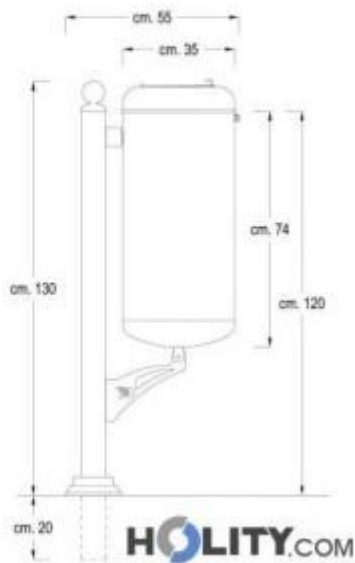

Expired medicine collection bin h140_303

Capacity: 70 lt