



## Container for used battery collection h86\_244

Used battery container. Capacity 2 L. Dimensions W. 125 x D. 125 x H. 160 mm.

Classic container for the **collection of exhausted batteries**, with a clean and essential line and a square shape. The container has a capacity of **2 Liters**. Equipped with a lid with **calibrated opening** in powder-coated steel and a body in impact-resistant transparent polycarbonate. The container is equipped with a **seal** to prevent **leaks** of **acids** or **saline solutions**.

### **Technical Features:**

- Dimensions W. 125 x D. 125 x H. 160 mm
- Lid color: Purple RAL 4008
- Lid with calibrated opening in powder-coated steel
- Transparent polycarbonate structure
- Impact resistant
- Equipped with a seal

\*Images purely indicative

## INFORMATION

- **Height in millimeters** 160.000000
- **Width in millimeters** 125.000000
- **Depth in millimeters** 125.000000



HOLITY.COM



HOLITY.COM



HOLITY.COM

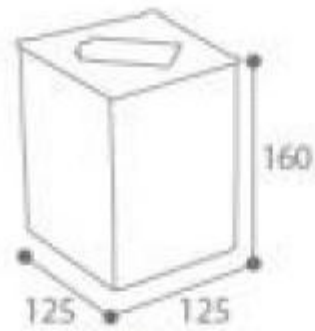

HOLITY.COM