



Concrete planter for urban furniture h319_81

Round planter for public spaces. Material: concrete. Available in various finishes. Dimensions: Ø90 x H65 cm.

Concrete planter for public space furniture, ideal for enhancing gardens, squares and municipal parks. Characterized by a **robust concrete structure** with a specific glossy anti-degradation water-repellent treatment for outdoor use. Equipped with a **decorative copper band** and internally provided with **handling and positioning hooks**.

Technical features:

- Dimensions: Ø90 x H65 cm
- Material: concrete
- Available in various finishes
- Weight: 330 kg

INFORMATION

- **Height in millimeters** 650.000000
- **Planter material** cemento
- **Diameter** 900.000000
- **shape** round



HOLITY.COM

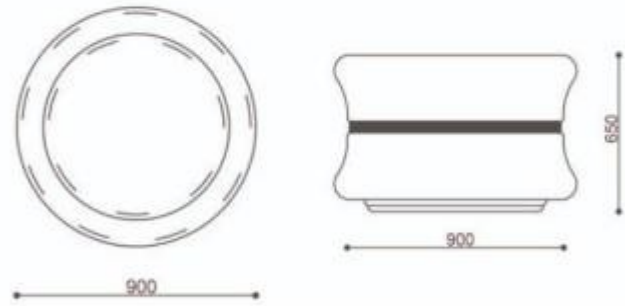

HOLITY.COM

Concrete planter for urban furniture h319_81

Length in millimeters: 407 mm

Depth in millimeters: 400 mm

Height in millimeters: 399 mm

Diameter: 575 mm

Shape: rotonda